

"I want to create more opportunities for creative professionals to come together with different sectors."

Eunice designs spaces which bring to life her passion to support creativity in her **community**.

Third spaces fostering creative collaborations



The **government** is encouraging collaboration with creative industries for placemaking to create sustainable and cultural solutions for different parts of the Philippines.



How does it work in the **local context?**

Placemaking

Tranquilo Coffee

"If a person is successful, the person is *tranquilo*"
Bicol saying



Inspired by her **roots** in the Bicol region

Mayon Volcano

"I hope that within this small space big ideas will be created."



Placemaking space for **local communities** to use for their **creative expressions** and innovative events to uplift young professionals and designers.

Recommendations from Eunice

What to read?

Designing Futures
by B. Gross & E. Mandir

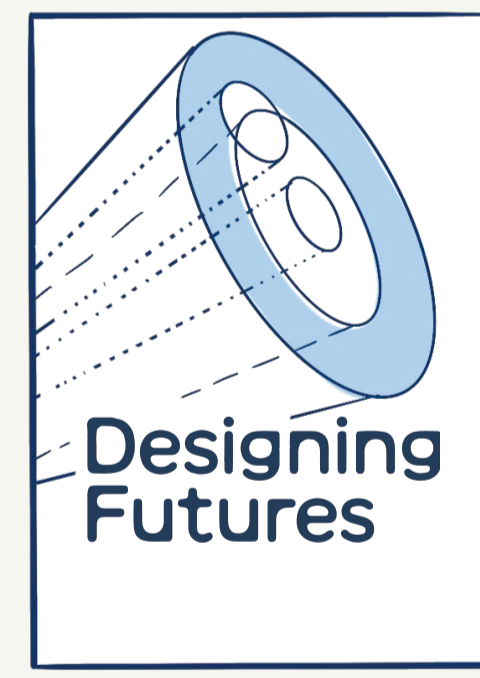

Who to follow?

@skrumblmnl on Instagram to see the development of the new dessert Eunice is creating!

What to watch?

A fun watch is **Unchained Reaction** on Discovery Channel, a game show where people of different disciplines like engineers, artists, scientists design chain reaction machines.

Tranquilo
adjective
not wavered easily by obstacles, having inner peace and a clear sense of what matters for oneself.

Placemaking
verb
to create **dynamic** places - not just focused on the market where there is an exchange of products, also an exchange of **cultural** values.

Glossary

Favourite book
Change by Design by Tim Brown

Favourite sports
Bowling and Badminton

Pet
Dog named Chewie

Favourite foods
Ramen and Sinigang na Baboy

Favourite designers
David Kelley, Zaha Hadid, Kenneth Cobonpue

Hobbies
Read, Travel, Hike, Play the guitar and the piano

157 cm

Meet Joy D. Eunice Ison
29, Philippines

Eunice holds a degree in **industrial design** from the University of Santo Tomas and an MBA from Ateneo Graduate School of Business. She is the founder and design director of **Eu.Nik Design Solutions** and chief business officer at **Higos at Uigma Corporation**.

"My vision as a designer is to design sustainable solutions for the wellbeing of people and the planet through creativity, innovation and strategic business methods."

We want to **hear from you!** Look out on social media for updates to stay engaged.

Tune in to the **Next in Line** podcast to join the conversation!



FOLDING INSTRUCTIONS

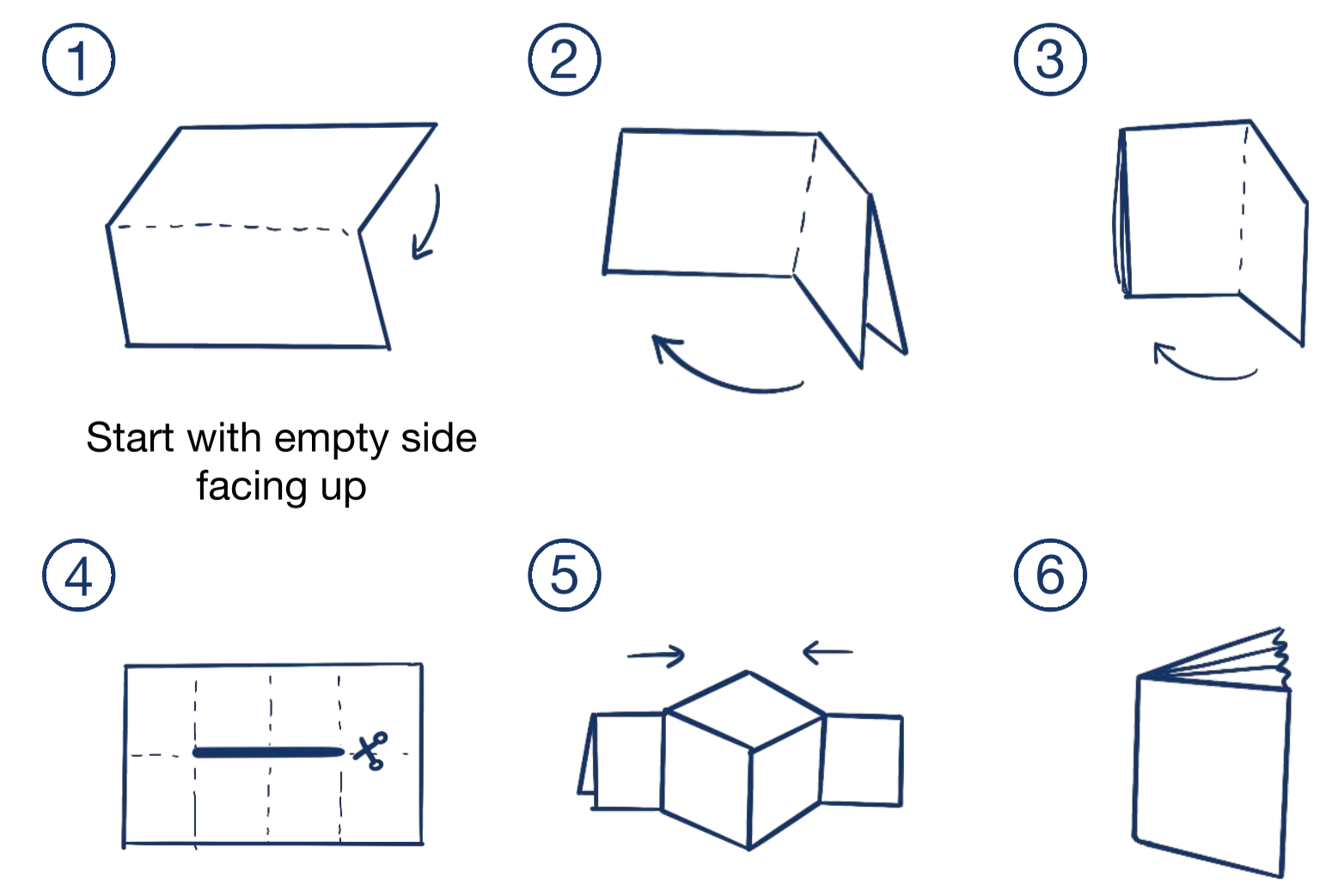

Creators:
Natalia Enriquez Martinez
Sushmitha Nair
Başak Onbaşıoğlu
Andrea Robredo Cernicchiaro

In this episode, our guest discusses...

- Exploring **solutions beyond physical products** while emphasizing the need to break habits and address environmental challenges **holistically**
- Opportunities in placemaking as a way to shape and improve **communities**
- Taking inspiration from her **roots** to design her new initiative
- Finding her **purpose** and **passion** as a designer

NEXT IN LINE DESIGN

Placemaking and Design Entrepreneurship

Hosted by: Alexis Divis

